

RIGID THERMAL CONTAINMENT

Triad Flooring

SINGLE & DOUBLE DOORS

01 APPLICATIONS: Rigid doors are one of the most popular products in our containment portfolio, and are used to seal off the end of a data center aisle and keep hot and cold air from recirculating back into that aisle. Because each facility has unique needs, our doors are available in several base styles with a wide variety of options so your doors can be customized and manufactured specifically for your facility.

02 KEY FEATURES:

- Sturdy aluminum frame
 - No-threshold design
 - ASTM rated clear polycarbonate paneling
 - Satin anodized finish
-

03 AVAILABLE UPGRADES:

- Custom power coat and anodized color options
 - Digital locks
 - Corrugated door and side panels
 - Aluminum or plastic handles
-

04

WHAT SETS RLE'S RIGID THERMAL DOORS APART?

- **Custom Made For Your Facility** - Every facility is unique and so is each containment project. Each of our rigid doors are custom manufactured to ensure your project features doors with the best fit, function, and installation.
- **Extensive Experience** - Our professionals are ready to help you design, fit, and install the containment solution best suited for your facility.
- **Flexible Options** - Whether you need double or single doors, sliding doors with an auto close or manual close, pivot swinging doors, or our standard hinged doors, we offer the variety and options you need to fit each facility.

05 A VARIETY OF DOORS WITH OPTIONS TO SUIT EACH FACILITY: Designed for durability, fit, and function, our door solutions are custom designed and manufactured, and represent the ultimate value in rigid containment for data centers.



06 RIGID THERMAL DOORS: Double or single; sliding, pivot, or hinged.

Technical Specifications	
Door Frame Material Tensile Strength Finish Optional Upgrade	6560 T-6 temper aluminum 30,000 psi Clear satin anodize Custom anodize and powder coat colors
Paneling Standard Optional Upgrade	3mm clear polycarbonate 4.5mm clear polycarbonate; 650°F self-ignition rating; meets or exceeds ASTM E84

06

<p>Sliding Doors with Auto Closer - Available in Single and Double Door Configurations</p>	
<p>This double door is our most popular seller. The single door is ideal in cabinet to wall installations or where an obstruction does not allow a door to open in both directions.</p>	
<p>Included Features</p>	<p>Automatic closing door with soft close Door catch</p>
<p>Available Upgrades</p>	<p>Digital door lock Aluminum or plastic handles</p>

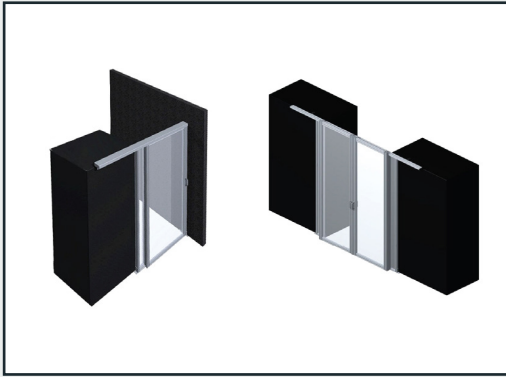

<p>Sliding Doors with Manual Close - Available in Single and Double Door Configurations</p>	
<p>The single version of this door is ideal in cabinet to wall installations or where an obstruction does not allow a door to open in both directions.</p>	
<p>Included Features</p>	<p>Door catch</p>
<p>Available Upgrades</p>	<p>Digital door lock Aluminum or plastic handles</p>

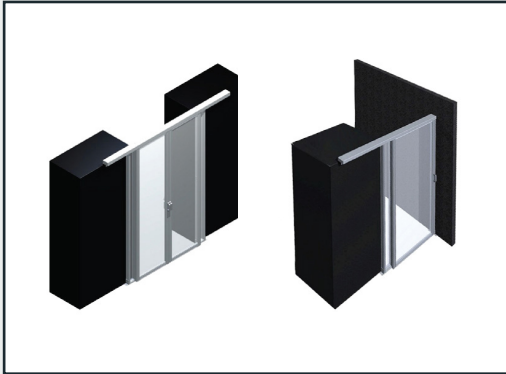

<p>Pivot Doors - Available in Single and Double Door Configurations</p>	
<p>This door pivots in both directions for hands-free operation. The double pivot door is easy to push a cart through. The single pivot door is a great narrow aisle door solution.</p>	
<p>Included Features</p>	<p>Hinge holds door in open position, pivots in both directions Dual swinging bar-style doors</p>
<p>Available Upgrades</p>	<p>Double door: Solid metal bottom panel</p>

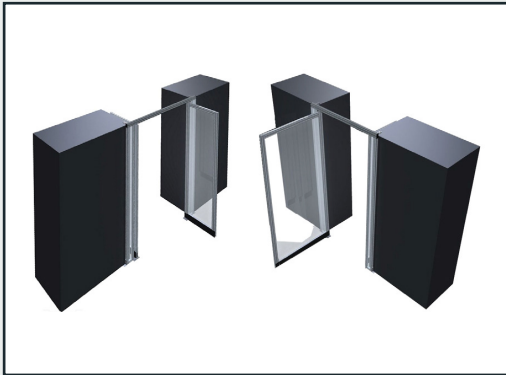

06

Hinged Doors - Available in Single Door Configurations Only

Our most affordable door, the single hinged door features the same build quality as our other doors without the added convenience features.

Included Features	Dual swinging hinge
Available Upgrades	Aluminum or plastic handles

