

AISLE CONTAINMENT

Triad Flooring

CUSTOM DESIGNED CONTAINMENT

01 APPLICATIONS: We source and stock a wide variety of containment resources and products to provide your facility with an affordable containment solution that fits your individualized requirements.

02 KEY FEATURES:

- Custom made solutions for both Hot and Cold Aisles
- Multiple options available to meet fire code compliance
- Comes pre-sized and custom cut for fast installation

03 WHAT SETS RLE'S AISLE CONTAINMENT APART?

- Can meet any design criteria including existing and new builds with non-standard rack layouts
- Infinitely customizable

04 CONTAINMENT IS NOT A ONE-SIZE-FITS-ALL ENTERPRISE: Our airflow and containment specialists realize each facility has unique needs and will collaborate with you to design a custom containment solution for your facility.



05 CEILING PANELS

Ceilings span the gap across the top of cabinets in cold aisle containment. They keep cold and hot air from mixing and are available in several styles to best suit your application.

Shrink-away ceiling panels are heat activated at 165° F and are designed to shrink and drop away in the event of a fire, allowing the fire suppression system to operate as required.

Mechanical ceilings can be built to either raise or drop and link directly to your facility’s fire suppression system. They reset easily and are made from the same heat activated material as our shrink-away ceilings, providing built-in redundancy.

Shrink-Away Ceiling Panels



Frame	
Material	6560 T-6 Temper Aluminum
Tensile Strength	30,000 psi
Typical Panel Size	Up to 26" x Up to 96"
Profile Height	1"
Paneling	
Material	
Color	
Smoke Deviation ASTM E84	
Material	
UL-R4036 rated for use under fire suppression systems	
FM-4651 approved for use under fire suppression systems	

Mechanical Ceiling Panels

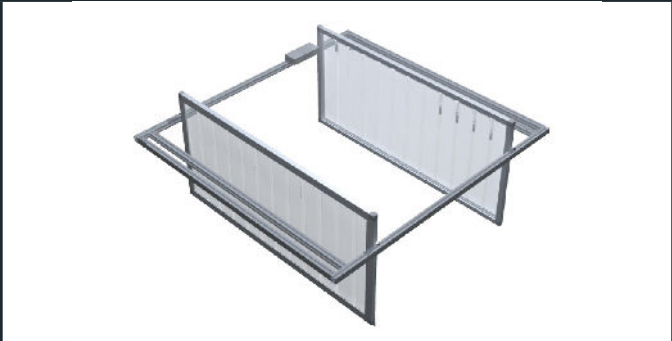

Frame	
Material	6560 T-6 Temper Aluminum
Tensile Strength	30,000 psi
Typical Panel Size	Up to 26" x Up to 96"
Profile Height	1"
Paneling	
Material	
Color	
Smoke Deviation ASTM E84	
Material	
UL-R4036 rated for use under fire suppression systems	
FM-4651 approved for use under fire suppression systems	

06 WALLS & DOORS

Thermal containment isolates hot and cold air, helps eliminate hot spots, and ensures only the hottest air is returned to the CRAC unit. This facilitates lower set points, helps prevent down time, and can lengthen the life of IT equipment.

Rigid containment is the most effective way to isolate hot and cold air in any facility and gives your space a clean, finished, professional look.

Soft containment products are a very affordable way to implement hot and cold aisle containment in any facility.

Rigid Walls and Doors



Door and Frame

Material	6560 T-6 Temper Aluminum	
Tensile Strength	30,000 psi	
Panel Options	Test	Result
Standard Clear Polycarbonate*	ASTM E-84	Class B
	ASTM D635	CC1
	ASTM D2843	<75
Premium Clear Polycarbonate	UL 94	V-0
	ASTM D635	CC1
	ASTM D2843	Passed
Clear PVC	FM 4910	Passed
	UL 94	V-0
	ASTM E-84	Class A
6 mm Twin-Wall Polycarbonate	ASTM E-84	Class A
	ASTM D635	CC1

* Rigid walls with width exceeding 30" will use 4.5mm polycarbonate. Rigid walls under 30" wide use 3mm polycarbonate.

Thermal Walls and Doors

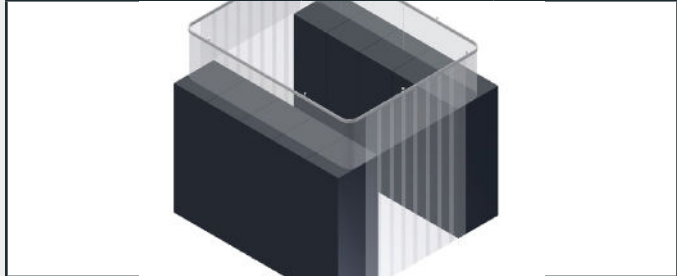

Track

Material	6091 T-5 Temper Aluminum	
Fire Suppression Fusible Links		
Heat Activated	135°	165°
Maximum Load	40 lbs	45 lbs
Minimum Load	3 lbs	3 lbs
Clear Vinyl		
NFPA 701 passed		

07 SINGLE DOORS

Rigid doors are one of the most popular products in our containment portfolio, and are used to seal off the end of a data center aisle and keep hot and cold air from recirculating back into that aisle. Because each facility has unique needs, our doors are available in several base styles with a wide variety of options so your doors can be customized and manufactured specifically for your facility.

Single Sliding Door		
		
Manual Close: Track		
Material	6091 T-5 Temper Aluminum	
Fire Suppression Fusible Links		
Heat Activated	135°	165°
Maximum Load	40 lbs	45 lbs
Minimum Load	3 lbs	3 lbs
Clear Vinyl		
NFPA 701 passed		
Auto Close: Frame		
Material	6560 T-6 Temper Aluminum	
Tensile Strength	30,000 psi	
Auto Close: Frame		
Material	15 mil Clear Polyvinyl Chloride	
Color	Clear	
Smoke Deviation ASTM E84	125 Test Result	
Flame Spread ASTM E84	6091 T-5 Temper Aluminum	
Meets or exceeds ASTM E84		
UL-R4036 and FM-4651 rated for use under fire suppression system		

Single Pivot Door	
	
Finish	
Standard Finish	Satin Anodize (Clear)
Upgrade Finish	Custom Anodize and Powder Coat Colors
Door and Frame	
Material	6560 T-6 Temper Aluminum
Tensile Strength	30,000 psi
Paneling - Lexan (High Optic Polycarbonate)	
Material	Polycarbonate
Color	Clear
Odor	Odorless
Thickness	4.5 mm
Self-ignition Temperature	650°
Meets or exceeds ASTM E84	

08 DOUBLE DOORS

Double Sliding Door	
	
Manual Close: Door and Frame	
Material	6560 T-6 Temper Aluminum
Tensile Strength	30,000 psi
Paneling - Lexan (High Optic Polycarbonate)	
Material	Polycarbonate
Color	Clear
Odor	Odorless
Thickness	4.5 mm
Self-ignition Temperature	650°
Meets or exceeds ASTM E84 Temperature	
Auto Close: Door and Frame	
Material	6560 T-6 Temper Aluminum
Tensile Strength	30,000 psi
Paneling - Lexan (High Optic Polycarbonate)	
Material	Polycarbonate
Color	Clear
Odor	Odorless
Thickness	4.5 mm
Self-ignition Temperature	650°
Meets or exceeds ASTM E84	

Double Pivot Door	
	
Door and Frame	
Material	6560 T-6 Temper Aluminum
Tensile Strength	30,000 psi
Paneling - Lexan (High Optic Polycarbonate)	
Material	Polycarbonate
Color	Clear
Odor	Odorless
Thickness	4.5 mm
Self-ignition Temperature	650°
Meets or exceeds ASTM E84	