

# ALUMINUM PANEL

Triad Flooring

## RAISED FLOOR PANEL

**01 APPLICATIONS:** Open area airflow panels are designed to provide maximum airflow distribution that fits into most raised floor systems.

Contact RLE to ensure a personalized fit for your facility.

**02 KEY FEATURES:**

- 55% open area
- Powder coat finish
- Grate design
- Imperial sizing 24" x 24" (610mm x 610mm)

**03 WHAT SETS RLE'S ALUMINUM PANEL APART?**

- Lightweight
- Our most economical option
- In-stock and ready to ship allowing for quick turnaround
- Load Rating up to 1,250 pounds

**04 COST EFFECTIVE AIRFLOW SOLUTIONS FOR EVERY FACILITY:** The Triad die-cast aluminum panel is RLE's most economical option, is designed to fit into most common flooring systems.

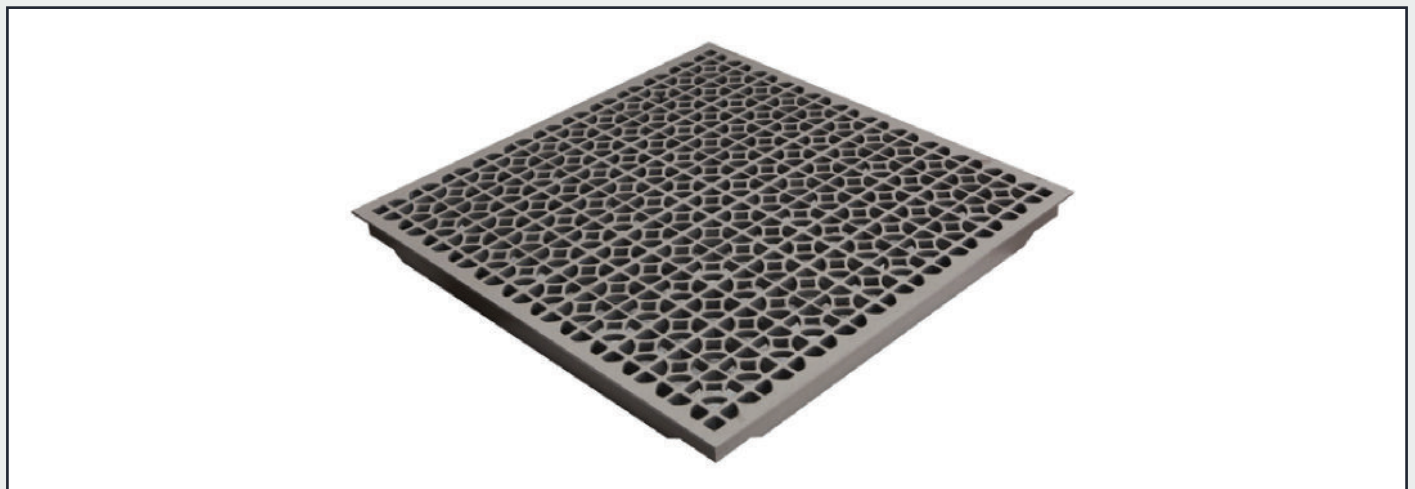

# 05 CAST ALUMINUM PANEL: Compatible with most new and existing raised floor systems

Product Codes	
<b>1250AL-55-GFT</b>	Cast Aluminum panel; Imperial sized (24" x 24"); 1250 lbs load rating; grey flek powder coat
<b>1250AL-55-CWT</b>	Cast Aluminum panel; Imperial sized (24" x 24"); 1250 lbs load rating; crystal white powder coat

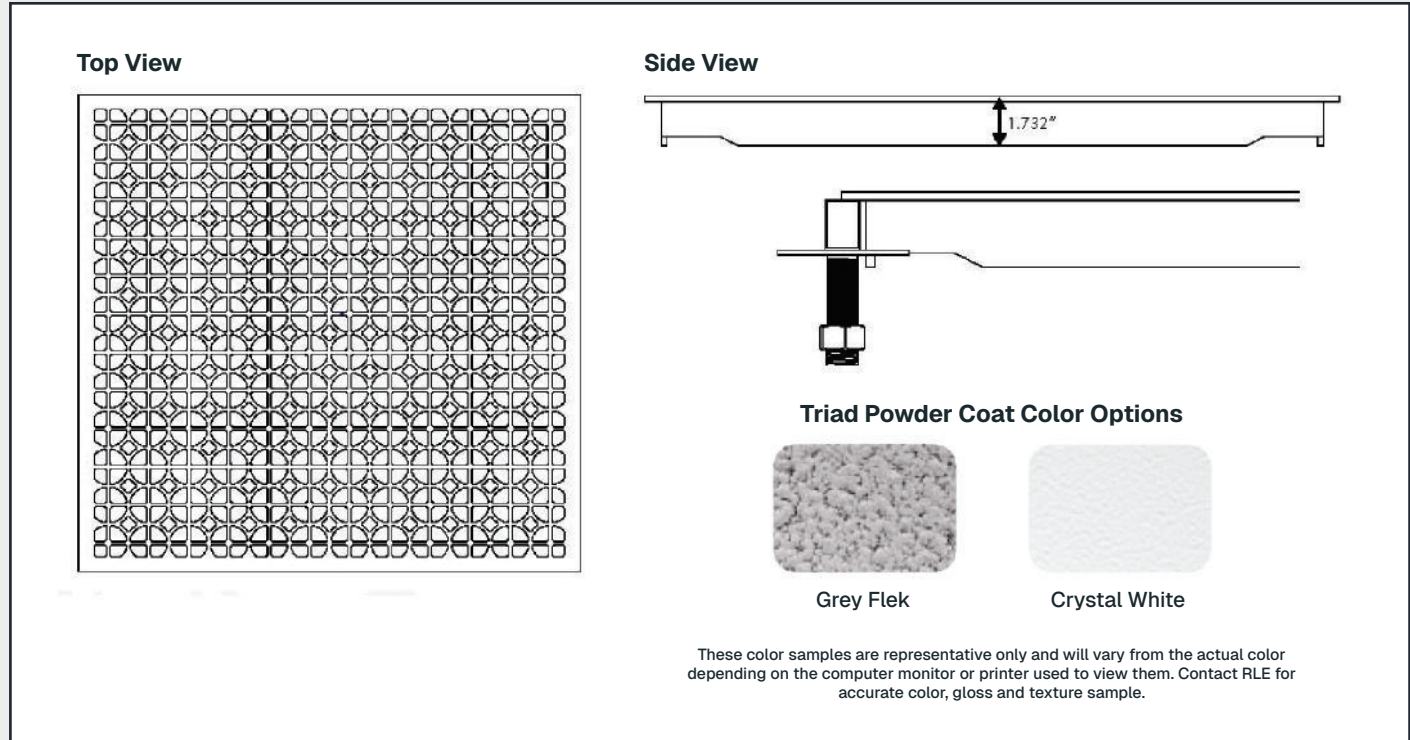

# 06 Technical Specifications

<b>Style</b>	Perferated
<b>Composition</b>	Cast Aluminum
<b>Included Features</b>	Die cast aluminum construction, Powdercoat finish, 55% open area
<b>Finish</b>	Powder Coat Colors: Grey flek or crystal white.
<b>Compatibility</b>	Compatible with most new and existing raised floor systems. Contact RLE to ensure a personalized fit.
<b>Dimension and Weight</b>	Imperial sizing only; 24" x 24" (610mm x 610mm); 18 lbs. (8.2 kg)
<b>Load Rating</b>	Available in 1250 lb (Imperial) These load ratings are static load ratings only. Please contact RLE for additional testing data.